

# FAIRLAND®

100% Green iGarden

## Spare Parts Catalog for X20 - 2024 Season



# CONTENTS

Spare Parts Picture .....	03
X20-09C.....	04-05
X20-11C.....	06-07
X20-14C.....	08-09
X20-16C.....	10-11
X20-18C.....	12-13
X20-22C.....	14-15
X20-26C.....	16-17
X20-32C.....	18-19
Spare Parts Picture .....	20-21
X20-26CT.....	22-23
X20-32CT .....	24-25
X20-40CT .....	26-27

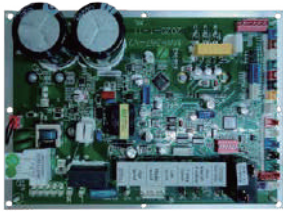

①

Integrated board (Heat&Cool)



②

Oval touch controller

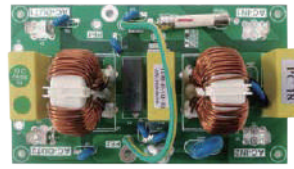

③

Power filter plate



④

Reactor (big)



⑤

Electronic expansion valve



⑥

4-way valve



⑦

Water flow switch



⑧

Fan motor



⑨

Full set of sensors



⑩

Compressor



⑪

Titanium heat exchanger (Heat&Cool)



⑫

Evaporator



⑬

High pressure protection switch



⑭

Low pressure protection switch



⑮

Low pressure valve



⑯

Liquid reservoir



⑰

Water union

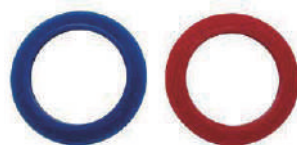

⑱

Water union gasket

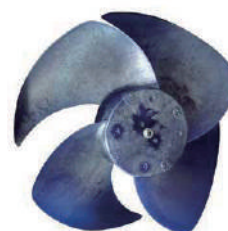

⑲

Fan



⑳

Drainage kit

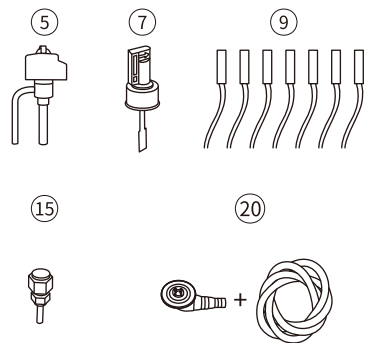
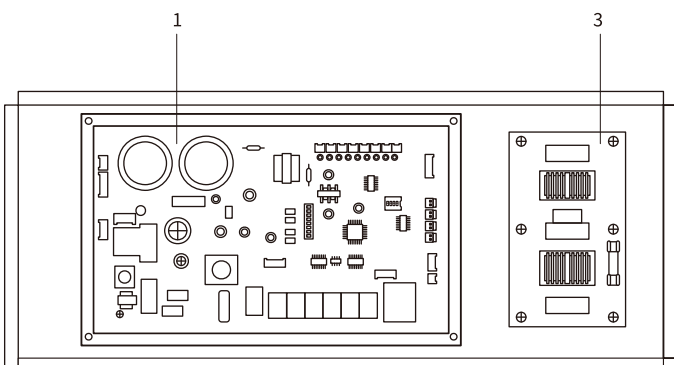
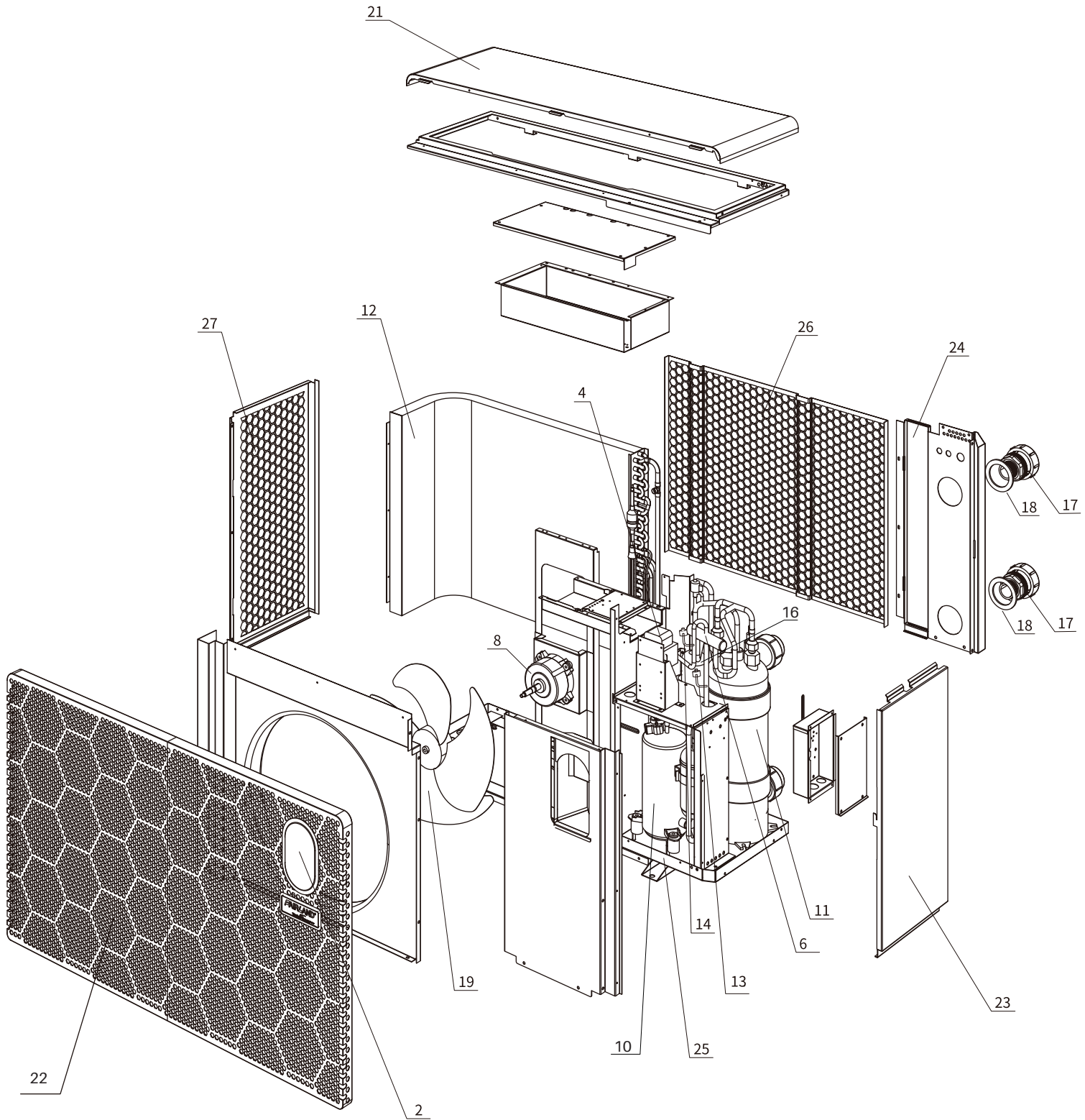

Position	Spare parts	Part number
1	Integrated board (Heat&Cool)	2005030200069A18
2	Oval touch controller	2005020900011
3	Power filter plate	033092360000
4	Reactor (big)	041301090000
5	Electronic expansion valve	2002010200022
6	4-way valve	006110080001
7	Water flow switch	040060620000
8	Fan motor	1201020100013
9	Full set of sensors	Z35043000400
10	Compressor	031064000000
11	Titanium heat exchanger (Heat&Cool)	2001020100151
12	Evaporator	1202010200136
13	High pressure protection switch	040050630000
14	Low pressure protection switch	040050130000
15	Low Pressure valve	006080500000
16	Liquid reservoir	1203020300012
17	Water union (Black, 50mm)	003990020000
18	Water union gasket	004980050003
19	Fan	007010140000
20	Drainage kit	Z03991700000
21	Top cover	1220020103716
22	Front Panel	1220020302239
23	Right Up Panel	1220020302072
24	Back Panel	1220020302241
25	Bottom board	1220020103717
26	Back mesh board	1220020302240
27	Left mesh board	1220020302069

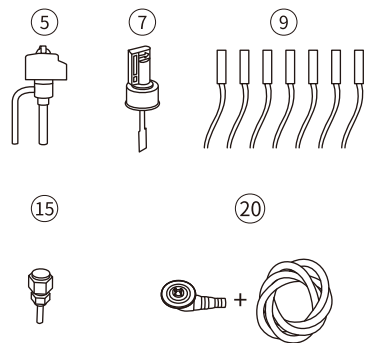
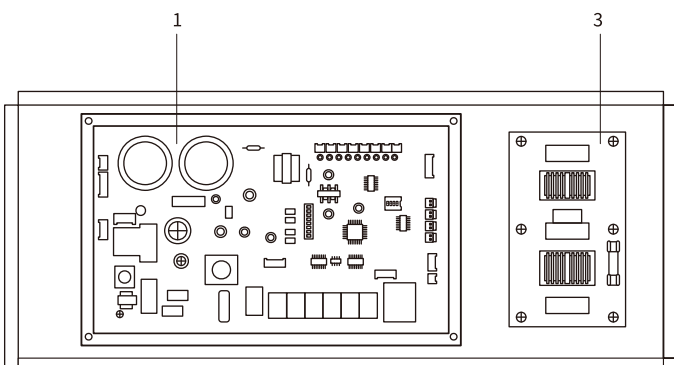
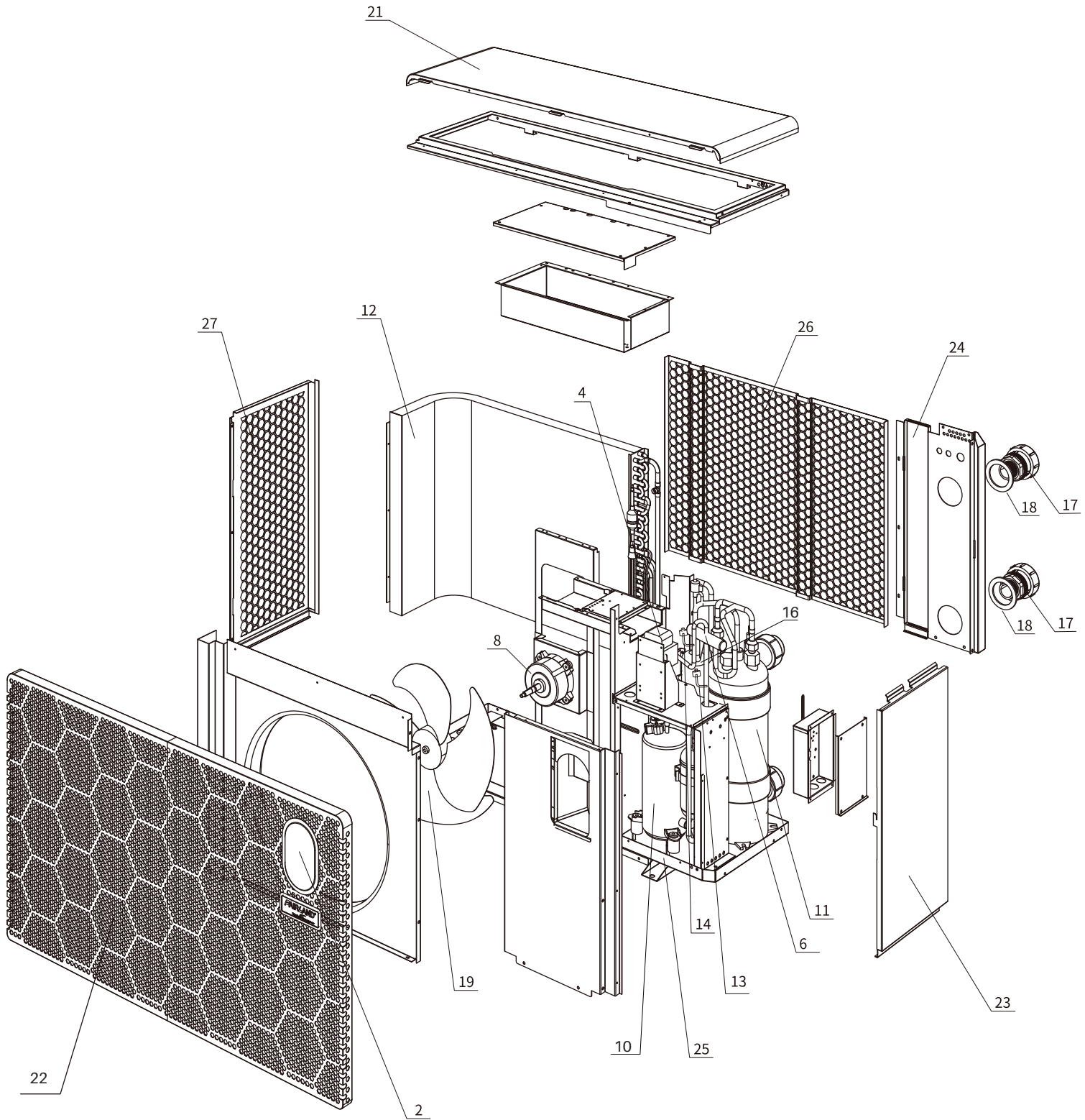

Position	Spare parts	Part number
1	Integrated board (Heat&Cool)	2005030200055A23
2	Oval touch controller	2005020900011
3	Power filter plate	033092360000
4	Reactor (big)	041301090000
5	Electronic expansion valve	2002010200022
6	4-way valve	006110080001
7	Water flow switch	040060620000
8	Fan motor	1201020100013
9	Full set of sensors	Z35043000400
10	Compressor	031064000000
11	Titanium heat exchanger (Heat&Cool)	2001020100151
12	Evaporator	1202010200136
13	High pressure protection switch	040050630000
14	Low pressure protection switch	040050130000
15	Low Pressure valve	006080500000
16	Liquid reservoir	1203020300012
17	Water union (Black, 50mm)	003990020000
18	Water union gasket	004980050003
19	Fan	007010140000
20	Drainage kit	Z03991700000
21	Top cover	1220020103716
22	Front Panel	1220020302239
23	Right Up Panel	1220020302072
24	Back Panel	1220020302241
25	Bottom board	1220020103717
26	Back mesh board	1220020302240
27	Left mesh board	1220020302069

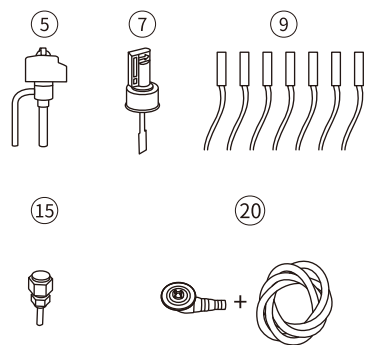
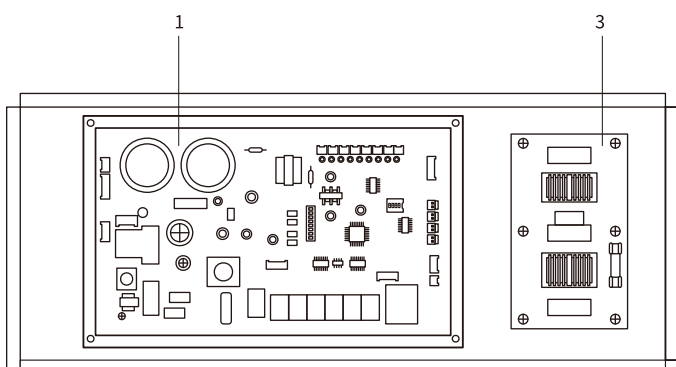
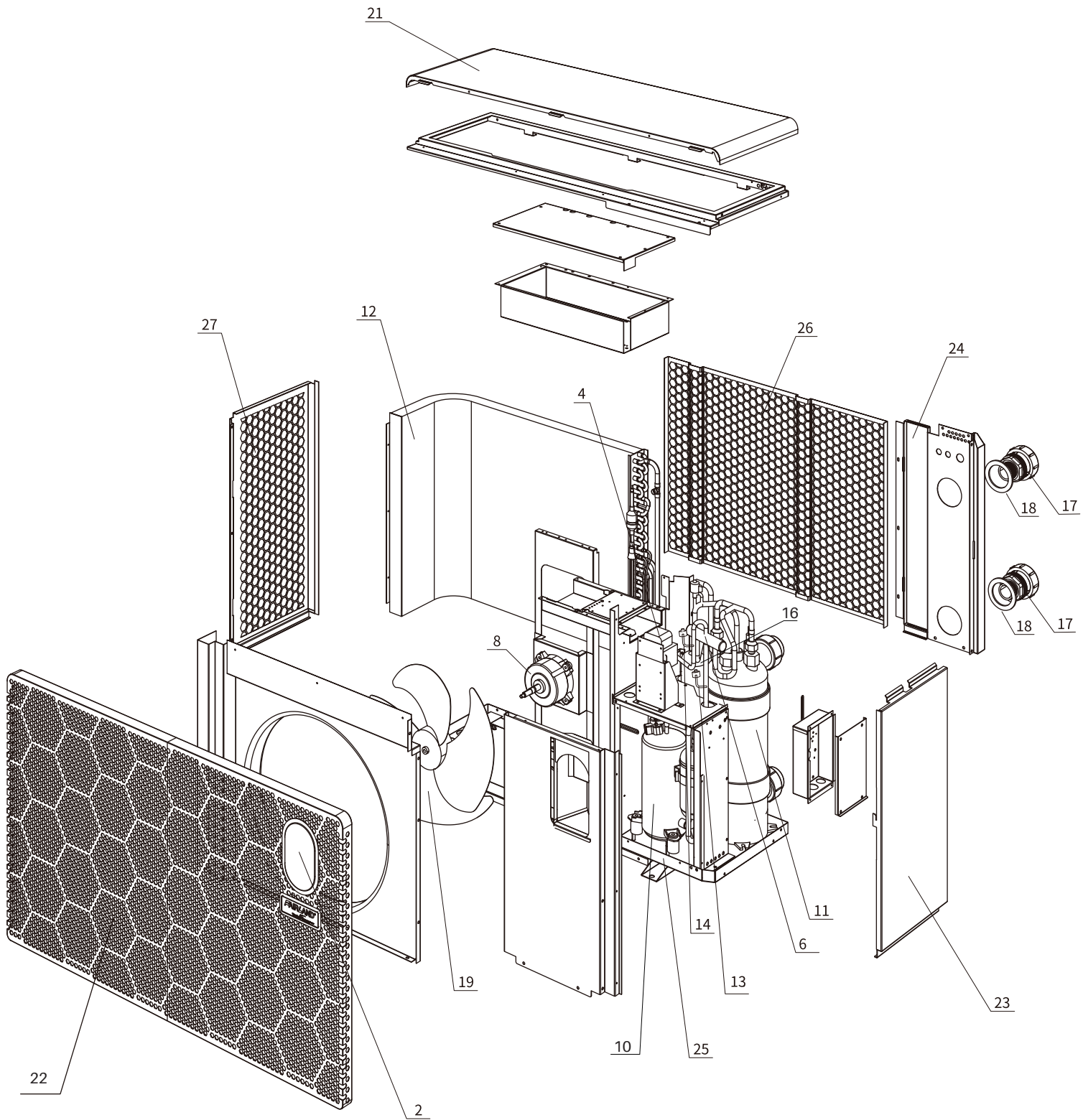



Position	Spare parts	Part number
1	Integrated board (Heat&Cool)	2005030200056A28
2	Oval touch controller	2005020900011
3	Power filter plate	033092330000
4	Reactor (big)	041301080000
5	Electronic expansion valve	2002010200023
6	4-way valve	006110080001
7	Water flow switch	040060620000
8	Fan motor	1201020100013
9	Full set of sensors	Z35043000400
10	Compressor	031064010000
11	Titanium heat exchanger (Heat&Cool)	2001020100149
12	Evaporator	1202010200130
13	High pressure protection switch	040050630000
14	Low pressure protection switch	040050130000
15	Low Pressure valve	006080500000
16	Liquid reservoir	1203020300010
17	Water union (Black, 50mm)	003990020000
18	Water union gasket	004980050003
19	Fan	007010140000
20	Drainage kit	Z03991700000
21	Top cover	1220020103694
22	Front Panel	1220020302222
23	Right Up Panel	1220020302072
24	Back Panel	1220020302224
25	Bottom board	1220020103695
26	Back mesh board	1220020302223
27	Left mesh board	1220020302069

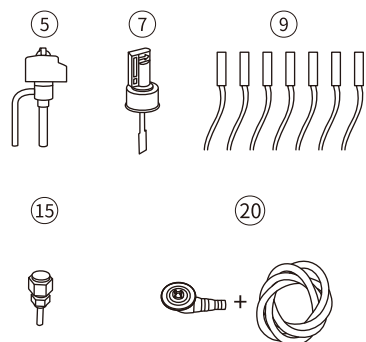
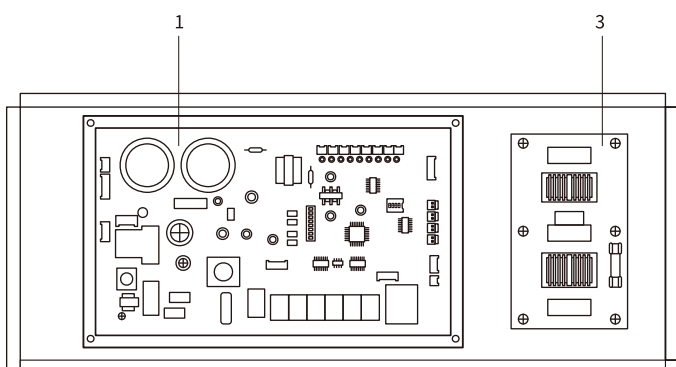
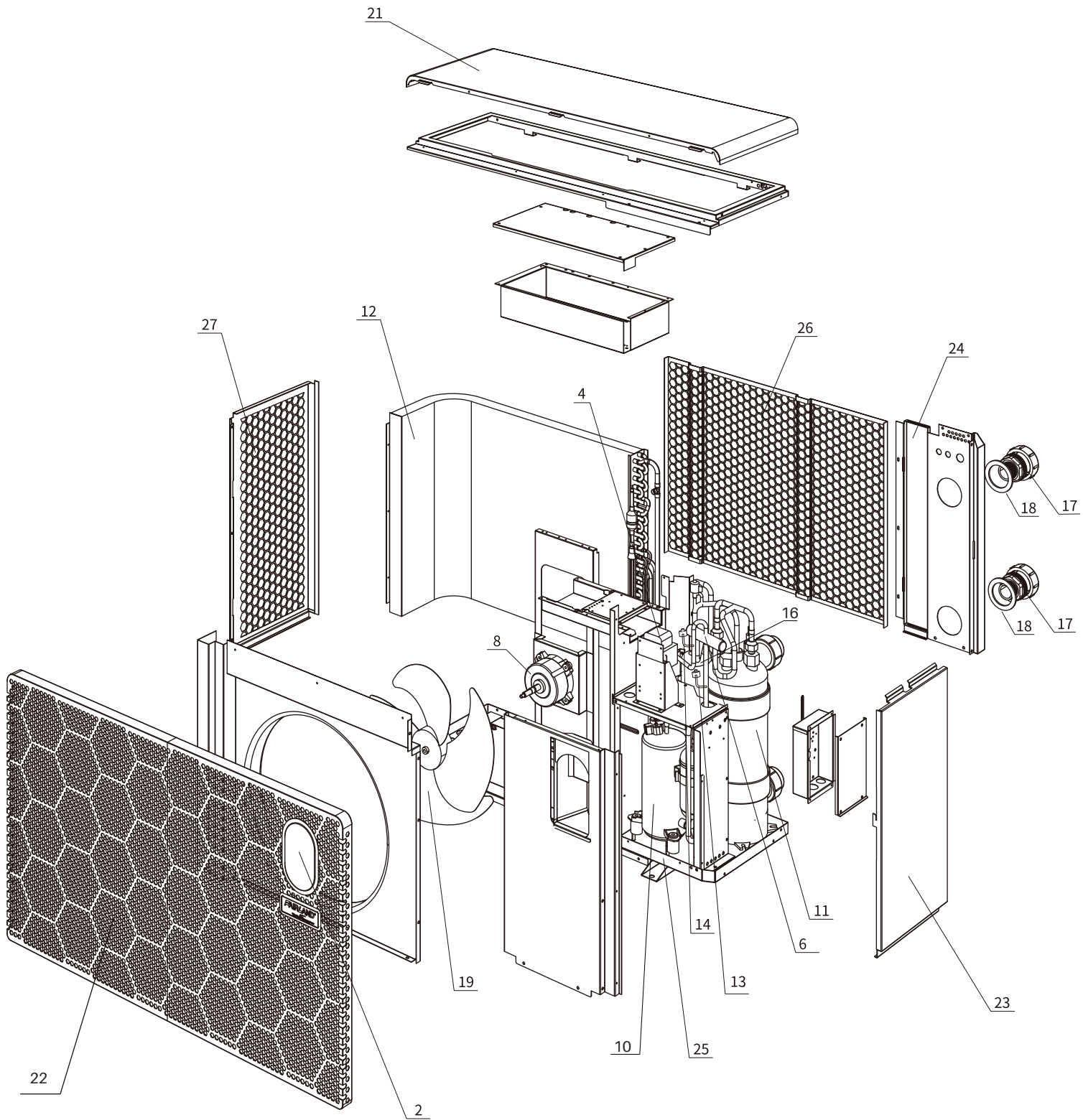

Position	Spare parts	Part number
1	Integrated board (Heat&Cool)	2005030200057A33
2	Oval touch controller	2005020900011
3	Power filter plate	033092330000
4	Reactor (big)	041301100000
5	Electronic expansion valve	006121000001
6	4-way valve	006110080001
7	Water flow switch	040060620000
8	Fan motor	1201020100073
9	Full set of sensors	Z35043000400
10	Compressor	031064020000
11	Titanium heat exchanger (Heat&Cool)	2001020100143
12	Evaporator	1202010200129
13	High pressure protection switch	040050630000
14	Low pressure protection switch	040050130000
15	Low Pressure valve	006080500000
16	Liquid reservoir	1203020300010
17	Water union (Black, 50mm)	003990020000
18	Water union gasket	004980050003
19	Fan	1220010200195
20	Drainage kit	Z03991700000
21	Top cover	1220020103412
22	Front Panel	1220020302068
23	Right Up Panel	1220020302072
24	Back Panel	1220020302071
25	Bottom board	1220020103413
26	Back mesh board	1220020302070
27	Left mesh board	1220020302069

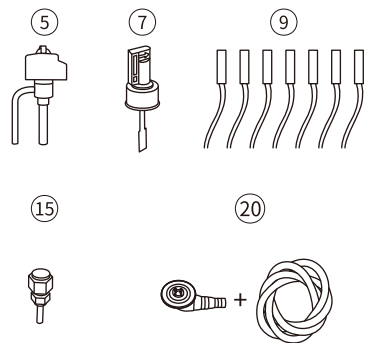
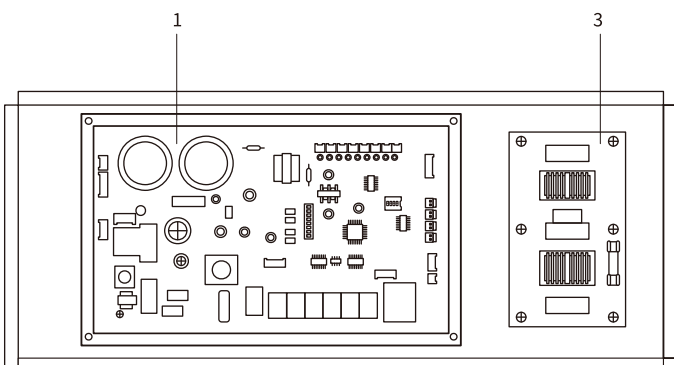
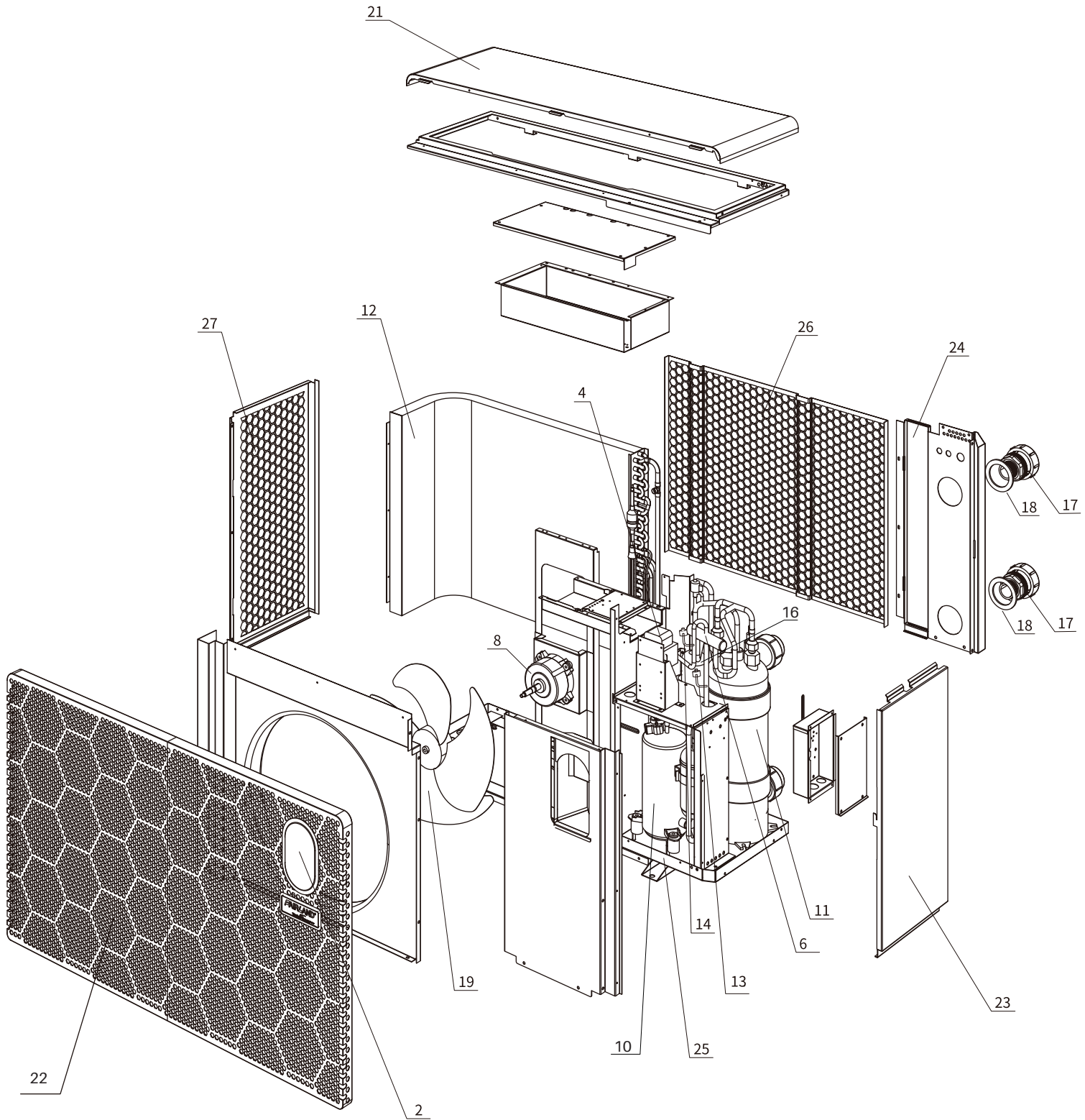

Position	Spare parts	Part number
1	Integrated board (Heat&Cool)	2005030200071A36
2	Oval touch controller	2005020900011
3	Power filter plate	033092330000
4	Reactor (big)	041301100000
5	Electronic expansion valve	006121000001
6	4-way valve	006110080001
7	Water flow switch	040060620000
8	Fan motor	1201020100073
9	Full set of sensors	Z35043000400
10	Compressor	1201010300052
11	Titanium heat exchanger (Heat&Cool)	2001020100185
12	Evaporator	1202010200129
13	High pressure protection switch	040050630000
14	Low pressure protection switch	040050130000
15	Low Pressure valve	006080500000
16	Liquid reservoir	1203020300010
17	Water union (Black, 50mm)	003990020000
18	Water union gasket	004980050003
19	Fan	1220010200195
20	Drainage kit	Z03991700000
21	Top cover	1220020103412
22	Front Panel	1220020302068
23	Right Up Panel	1220020302072
24	Back Panel	1220020302740
25	Bottom board	1220020104324
26	Back mesh board	1220020302070
27	Left mesh board	1220020302069

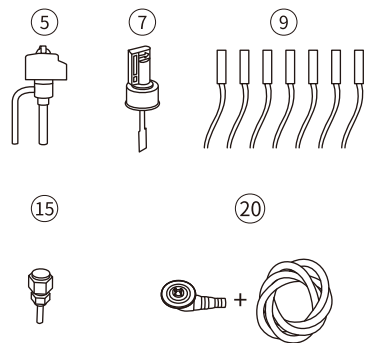
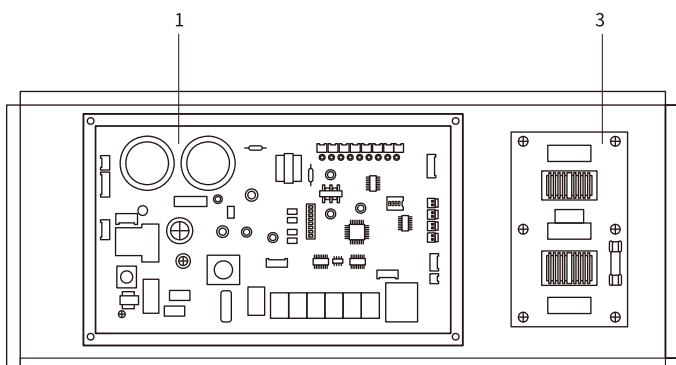
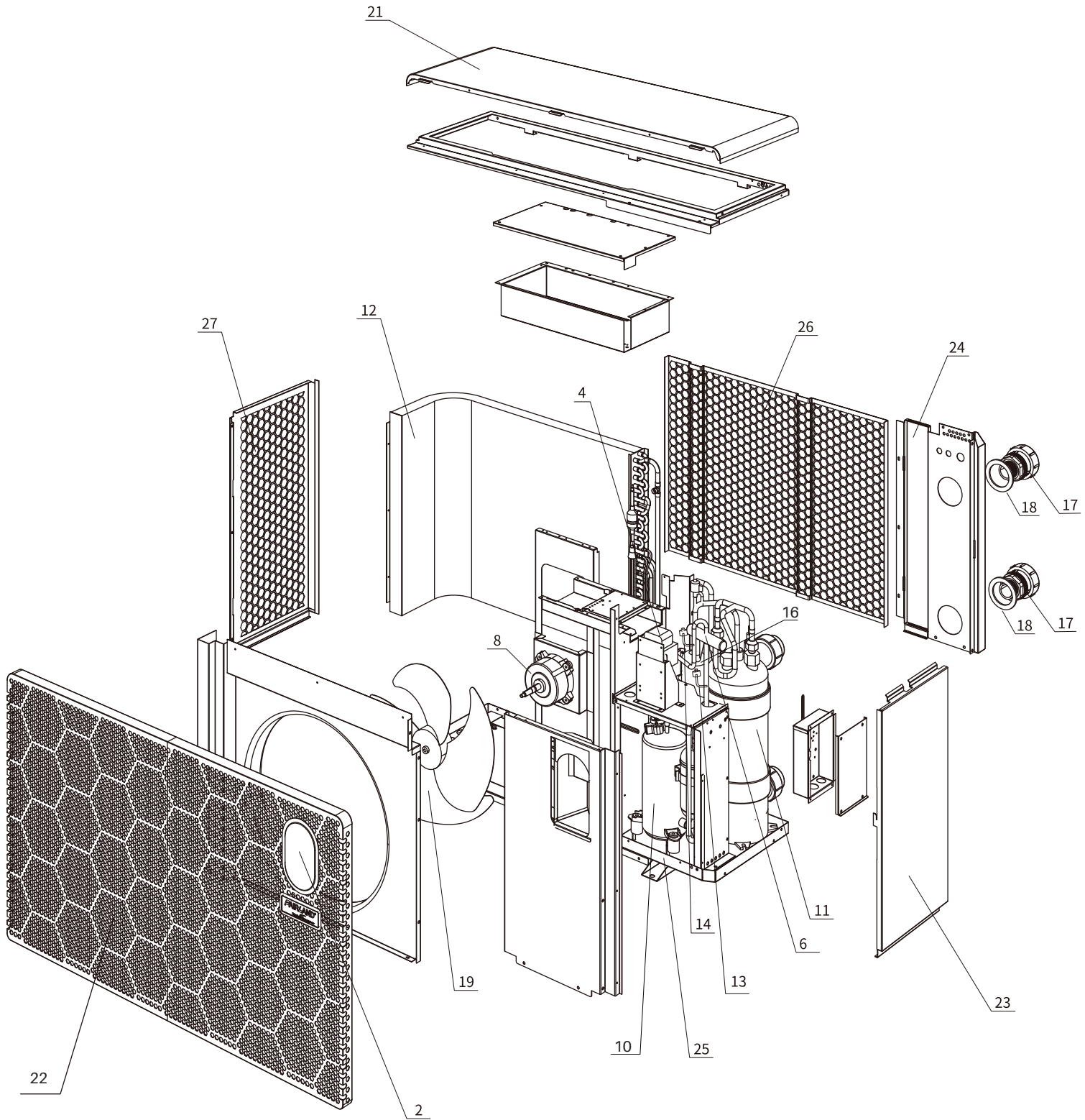

Position	Spare parts	Part number
1	Integrated board (Heat&Cool)	2005030200058A48
2	Oval touch controller	2005020900011
3	Power filter plate	033092340000
4	Reactor (big)	041301100000
5	Electronic expansion valve	006121010001
6	4-way valve	006110210001
7	Water flow switch	040060620000
8	Fan motor	032051700000
9	Full set of sensors	Z35043000400
10	Compressor	031064060000
11	Titanium heat exchanger (Heat&Cool)	2001020100150
12	Evaporator	1202010200131
13	High pressure protection switch	040050630000
14	Low pressure protection switch	040050130000
15	Low Pressure valve	006080500000
16	Liquid reservoir	1203020300010
17	Water union (Black, 50mm)	003990020000
18	Water union gasket	004980050003
19	Fan	007010070000
20	Drainage kit	Z03991700000
21	Top cover	1220020103701
22	Front Panel	1220020302232
23	Right Up Panel	1220020302236
24	Back Panel	1220020302235
25	Bottom board	1220020103702
26	Back mesh board	1220020302234
27	Left mesh board	1220020302233

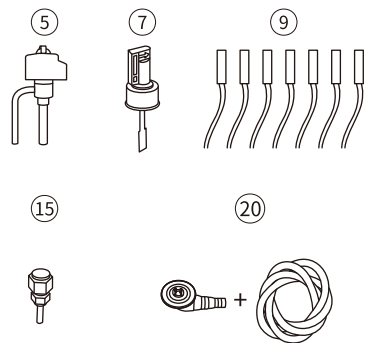
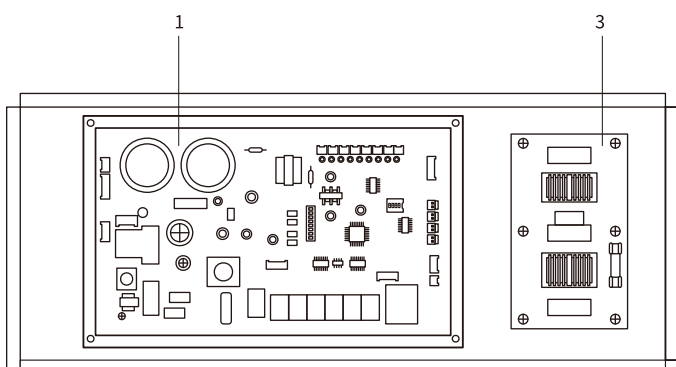
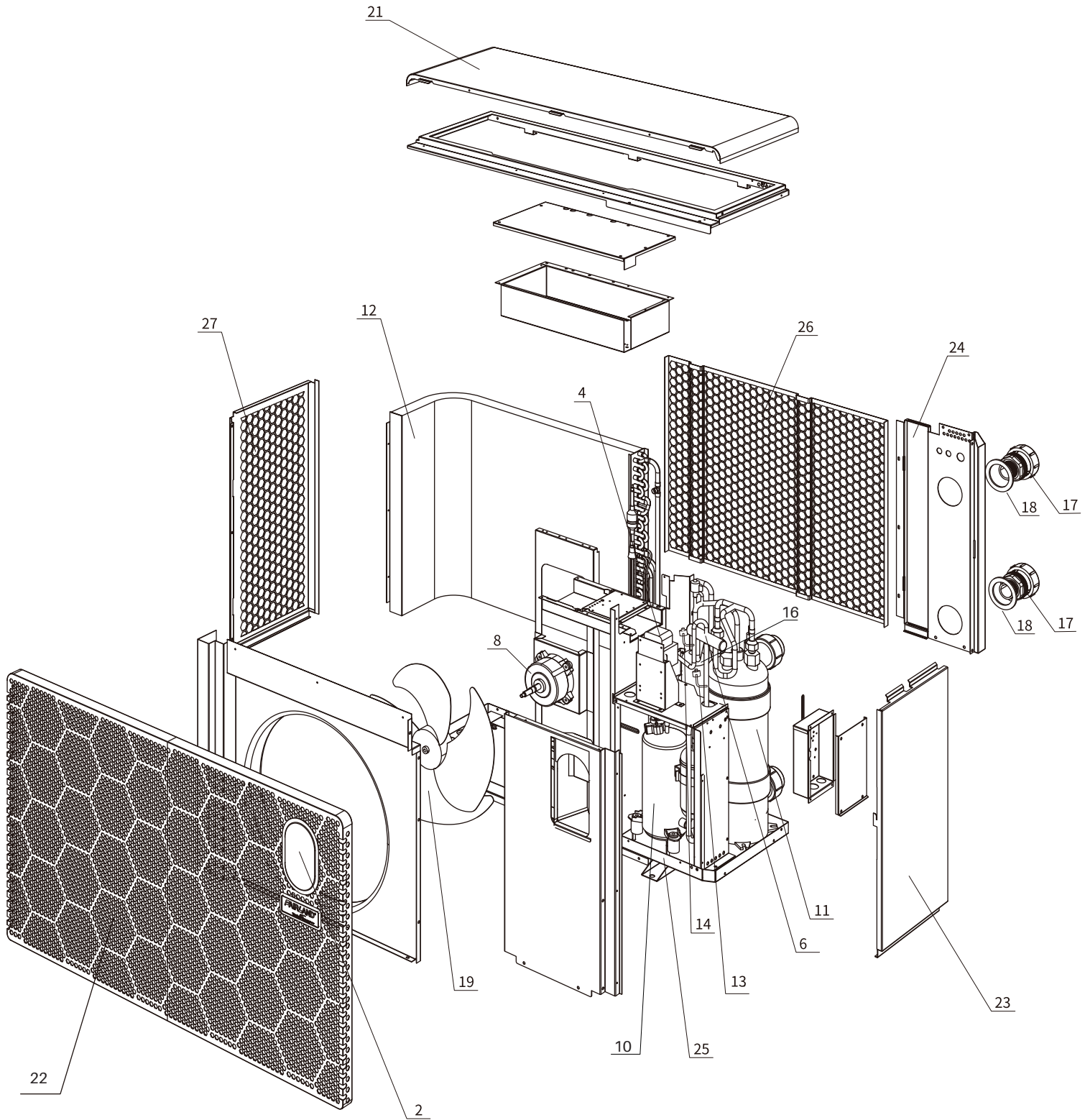



Position	Spare parts	Part number
1	Integrated board (Heat&Cool)	2005030200059A56
2	Oval touch controller	2005020900011
3	Power filter plate	033092370000
4	Reactor (big)	041301110000
5	Electronic expansion valve	006121110001
6	4-way valve	2002010100014
7	Water flow switch	040060620000
8	Fan motor	032051640000
9	Full set of sensors	Z35043000400
10	Compressor	1201010300043
11	Titanium heat exchanger (Heat&Cool)	2001020100153
12	Evaporator	1202010200135
13	High pressure protection switch	040050630000
14	Low pressure protection switch	040050130000
15	Low Pressure valve	006080500000
16	Liquid reservoir	1203020300001
17	Water union (Black, 50mm)	003990020000
18	Water union gasket	004980050003
19	Fan	007010120000
20	Drainage kit	Z03991700000
21	Top cover	1220020103755
22	Front Panel	1220020302244
23	Right Up Panel	1220020302248
24	Back Panel	1220020302247
25	Bottom board	1220020103756
26	Back mesh board	1220020302246
27	Left mesh board	1220020302245

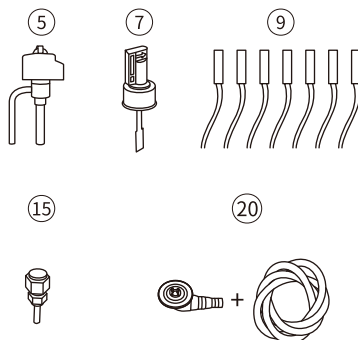
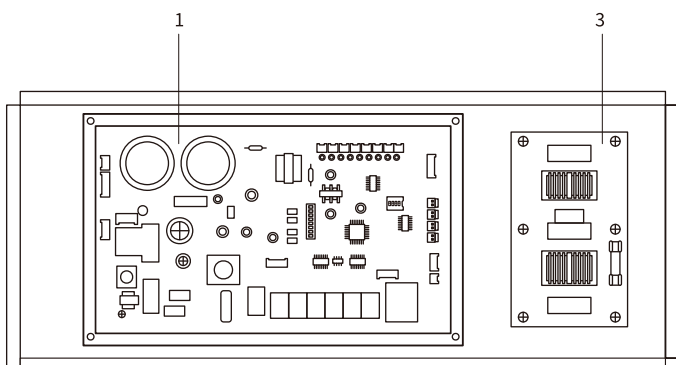
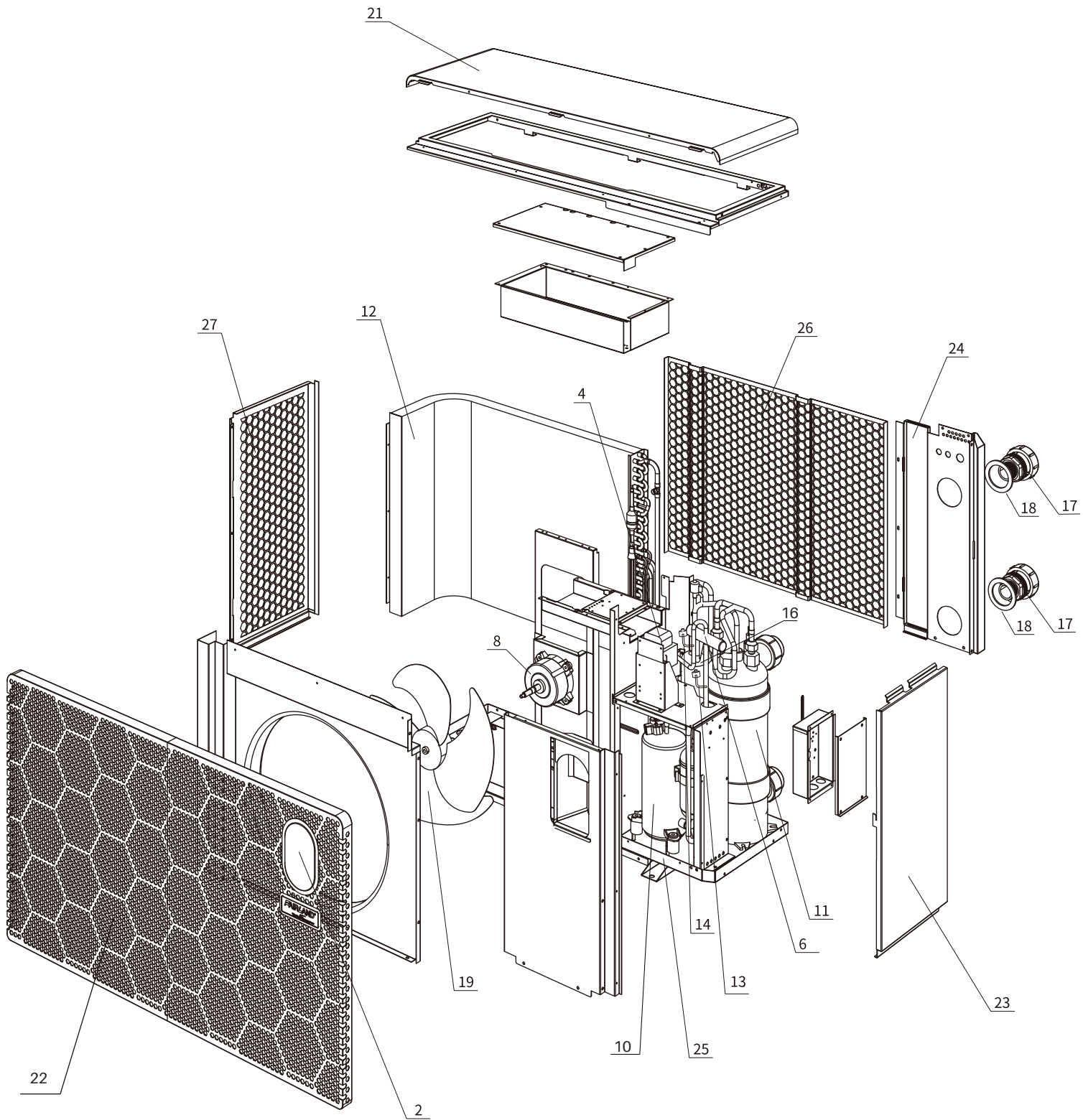

Position	Spare parts	Part number
1	Integrated board (Heat&Cool)	2005030200073A68
2	Oval touch controller	2005020900011
3	Power filter plate	033092370000
4	Reactor (big)	041301110000
5	Electronic expansion valve	2002010200025
6	4-way valve	2002010100014
7	Water flow switch	040060620000
8	Fan motor	032051720000
9	Full set of sensors	Z35043000400
10	Compressor	031064040000
11	Titanium heat exchanger (Heat&Cool)	2001020100192
12	Evaporator	1202010200141
13	High pressure protection switch	040050630000
14	Low pressure protection switch	040050130000
15	Low Pressure valve	006080500000
16	Liquid reservoir	1203020300001
17	Water union (Black, 50mm)	003990020000
18	Water union gasket	004980050003
19	Fan	007010080000
20	Drainage kit	Z03991700000
21	Top cover	1220020104341
22	Front Panel	1220020302764
23	Right Up Panel	1220020302768
24	Back Panel	1220020302767
25	Bottom board	1220020104086
26	Back mesh board	1220020302766
27	Left mesh board	1220020302765

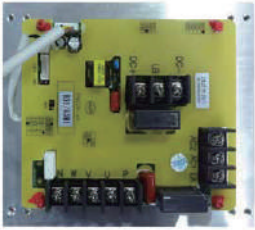

①

Inverter board

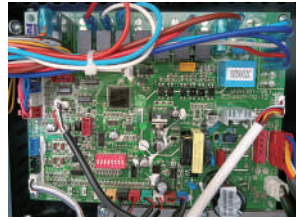

②

PC Board (Heat&Cool)



③

Oval touch controller



④

Contactor (3 phase relay)



⑤

Capacitor (3 phase)

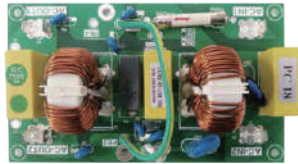

⑥

Power filter plate



⑦

Reactor (big)



⑧

Reactor (small)



⑨

Electronic expansion valve



⑩

4-way valve



⑪

Water flow switch



⑫

Fan motor



⑬

Full set of sensors



⑭

Compressor



⑮

Titanium heat exchanger (Heat&Cool)



⑯

Evaporator



⑰

High pressure protection switch



⑱

Low pressure protection switch



⑲

Low pressure valve



⑳

Liquid reservoir



②1

Water union

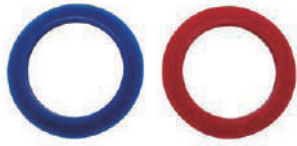

②2

Water union gasket



②3

Fan



②4

Drainage kit

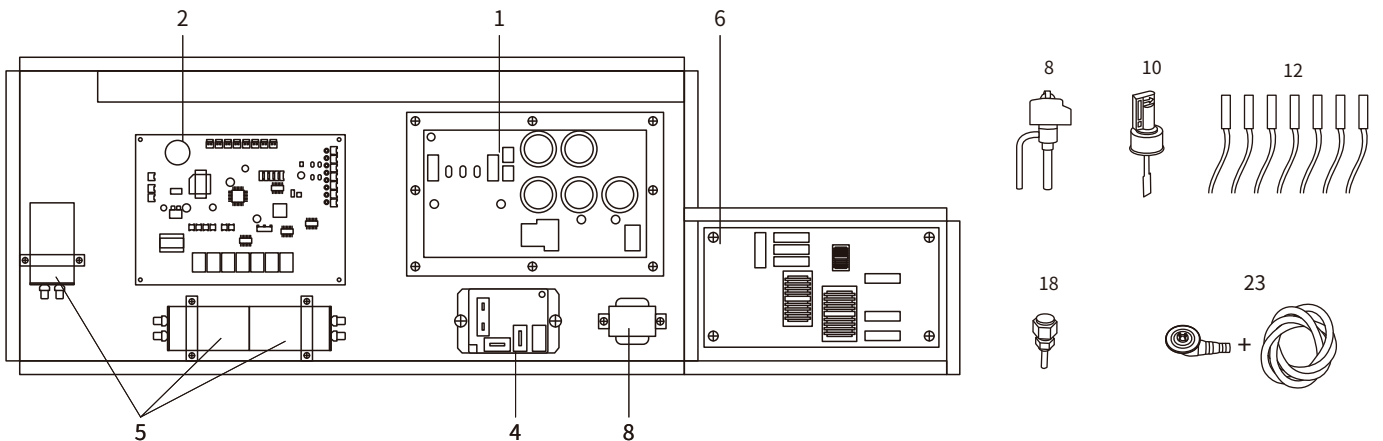
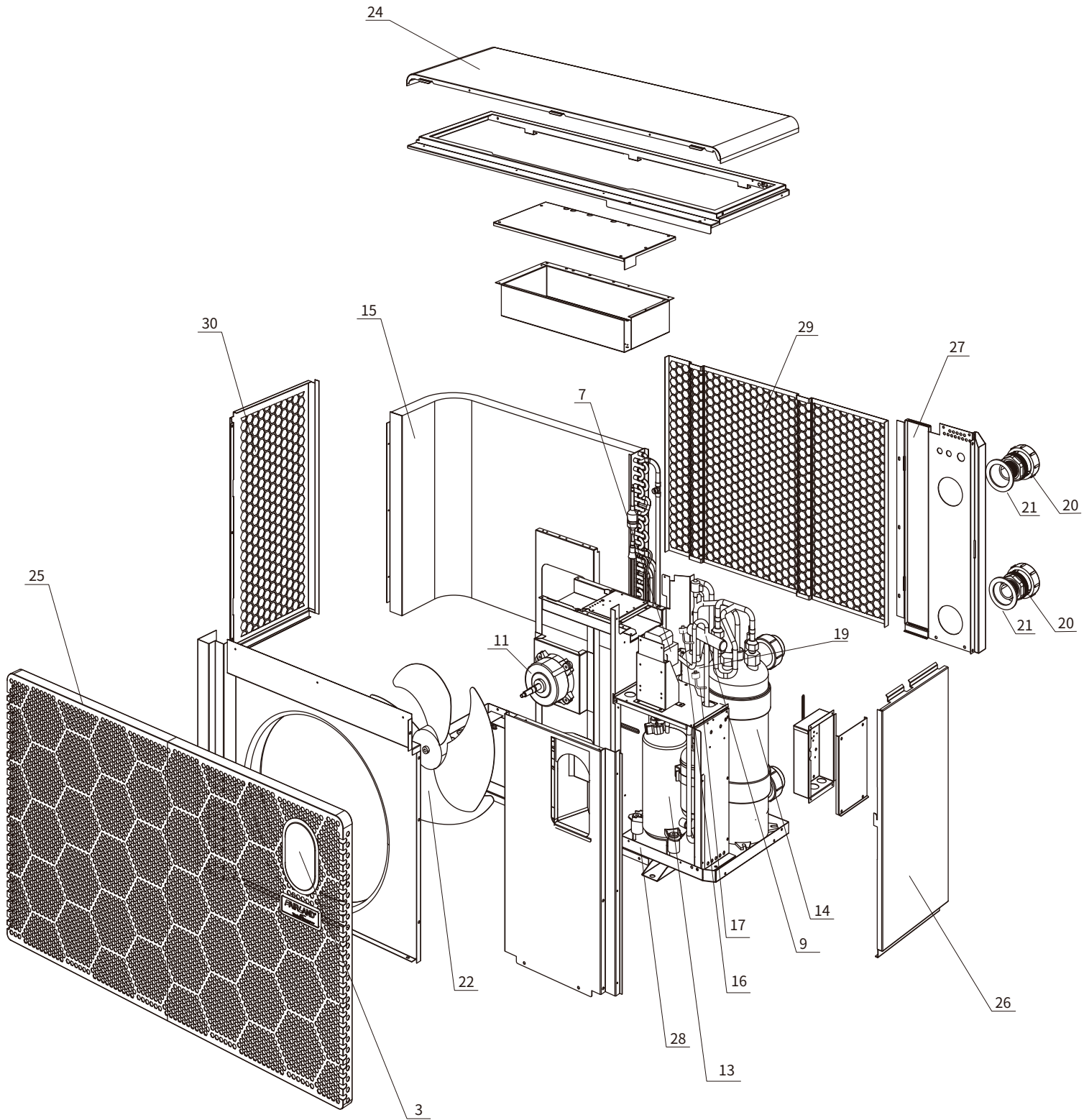

Position	Spare parts	Part number
1	Inverter board	2005030100102
2	PC board (Heat&Cool)	2005130100151A56s
3	Oval touch controller	2005020900011
4	Contactora (3 phase relay)	033990120000
5	Capacitor (3 phase)	041020250000
6	Power filter plate	033092370000
7	Reactor (big)	041301110000
8	Electronic expansion valve	2002010200030
9	4-way valve	2002010100014
10	Water flow switch	040060620000
11	Fan motor	032051640000
12	Full set of sensors	Z35043000400
13	Compressor	1201010300043
14	Titanium heat exchanger (Heat&Cool)	2001020100153
15	Evaporator	1202010200154
16	High pressure protection switch	040050630000
17	Low pressure protection switch	040050130000
18	Low Pressure valve	006080500000
19	Liquid reservoir	1203020300001
20	Water union (Black, 50mm)	003990020000
21	Water union gasket	004980050003
22	Fan	007010120000
23	Drainage kit	Z03991700000
24	Top cover	1220020104537
25	Front Panel	1220020302244
26	Right Up Panel	1220020302783
27	Back Panel	1220020302880
28	Bottom board	1220020104516
29	Back mesh board	1220020302891
30	Left mesh board	1220020302245

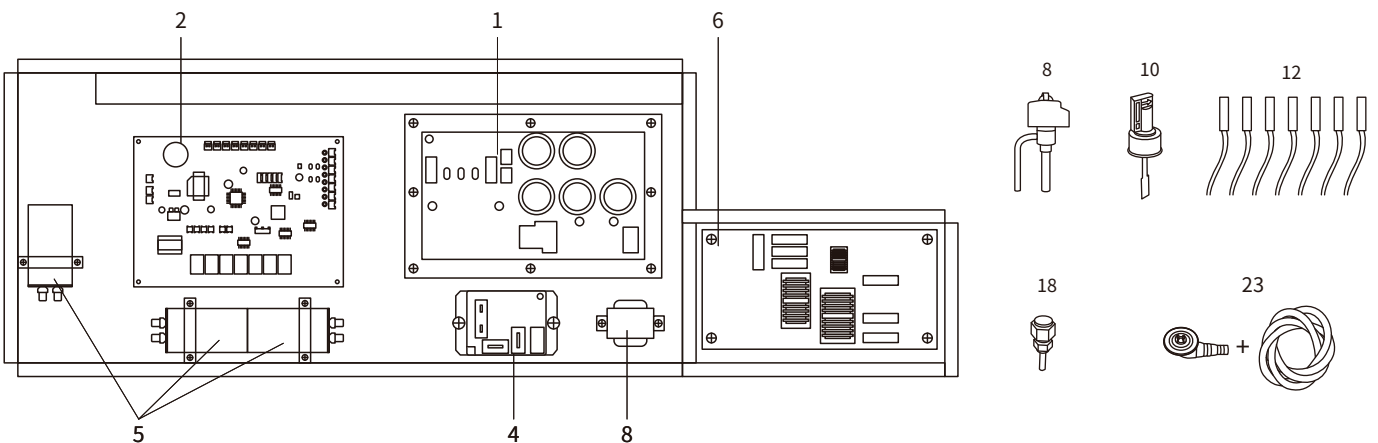
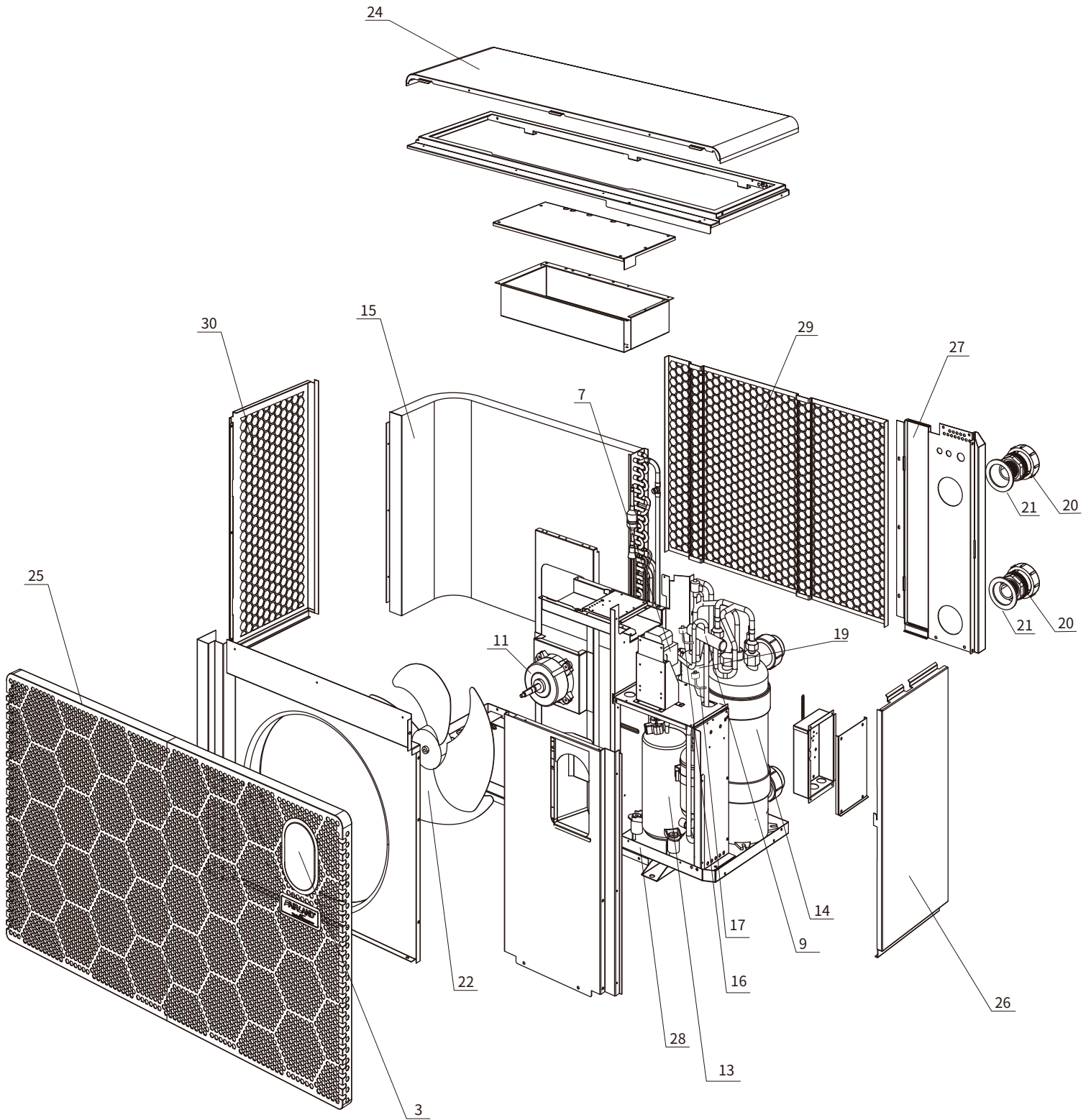



Position	Spare parts	Part number
1	Inverter board	2005030100098
2	PC board (Heat&Cool)	2005130100151A68s
3	Oval touch controller	2005020900011
4	Contactora (3 phase relay)	033990120000
5	Capacitor (3 phase)	041020250000
6	Power filter plate	033090650000
7	Reactor (big)	041301050000
8	Electronic expansion valve	2002010200025
9	4-way valve	2002010100014
10	Water flow switch	040060620000
11	Fan motor	032051720000
12	Full set of sensors	Z35043000400
13	Compressor	031064040000
14	Titanium heat exchanger (Heat&Cool)	2001020100192
15	Evaporator	1202010200141
16	High pressure protection switch	040050630000
17	Low pressure protection switch	040050130000
18	Low Pressure valve	006080500000
19	Liquid reservoir	1203020300001
20	Water union (Black, 50mm)	003990020000
21	Water union gasket	004980050003
22	Fan	007010080000
23	Drainage kit	Z03991700000
24	Top cover	1220020104341
25	Front Panel	1220020302764
26	Right Up Panel	1220020302768
27	Back Panel	1220020302767
28	Bottom board	1220020104086
29	Back mesh board	1220020302766
30	Left mesh board	1220020302765

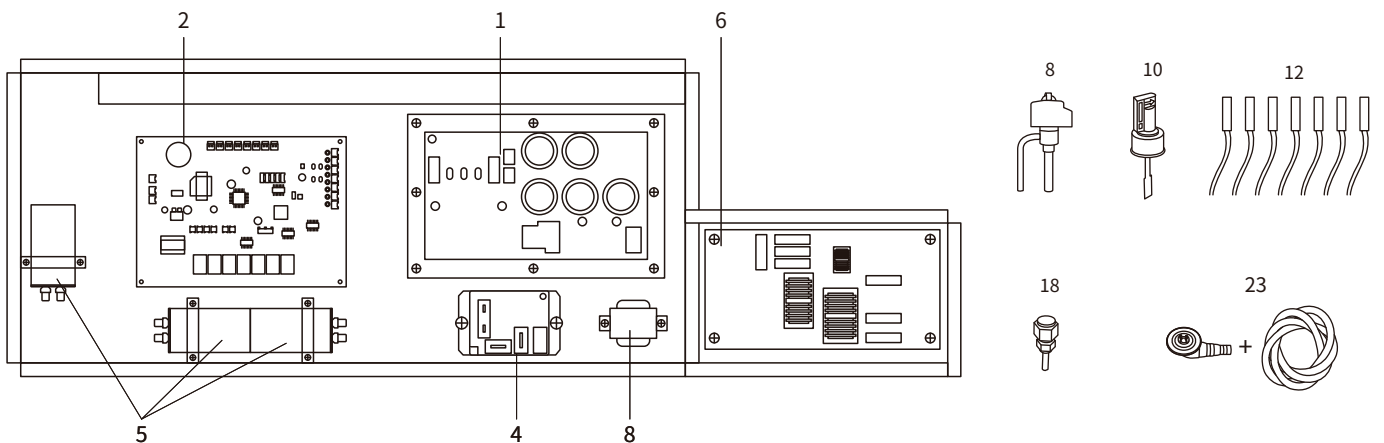
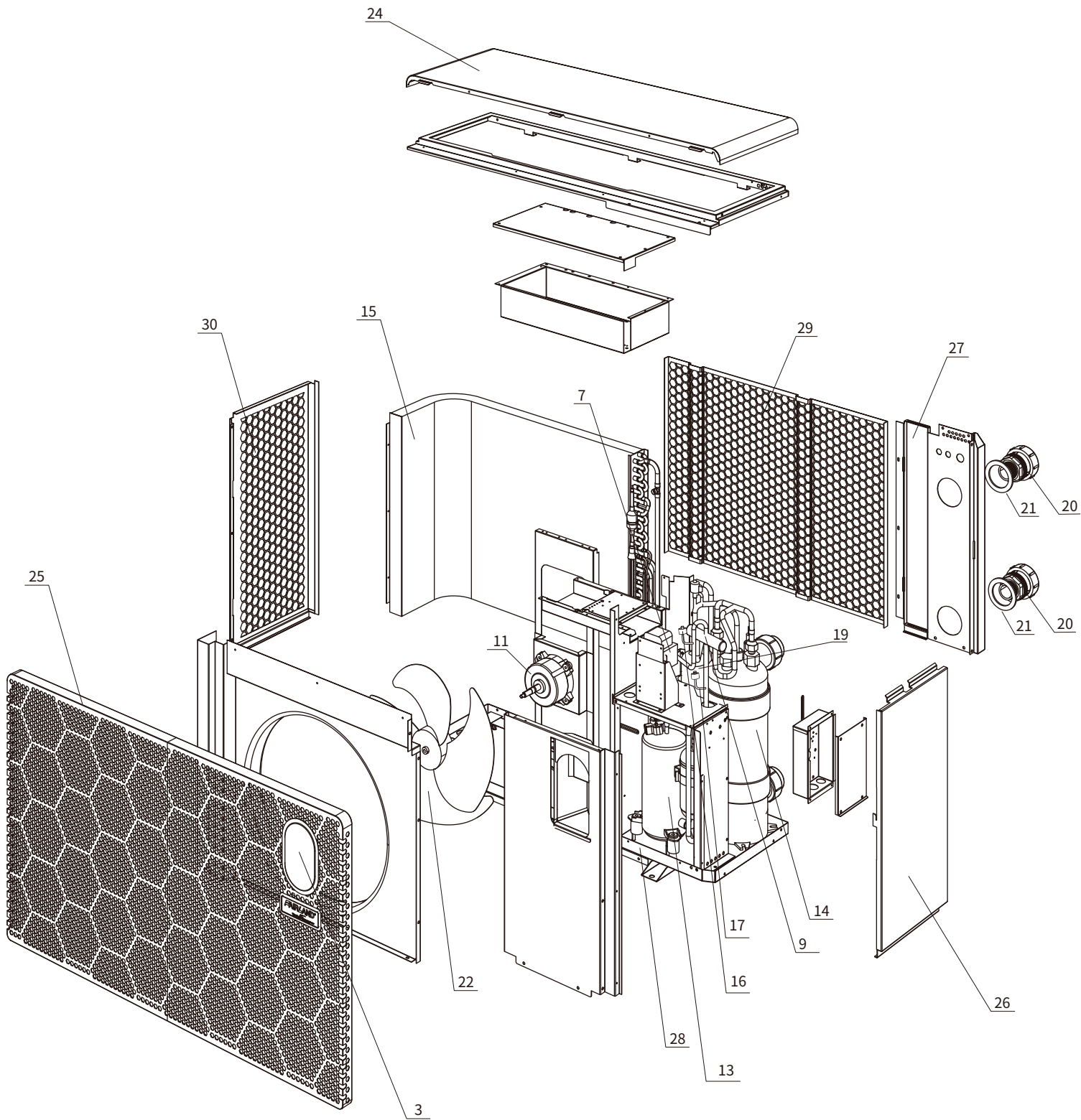

Position	Spare parts	Part number
1	Inverter board	2005030100097
2	PC board (Heat&Cool)	2005130100151A78s
3	Oval touch controller	2005020900011
4	Contactor (3 phase relay)	033990120000
5	Capacitor (3 phase)	041020350000
6	Power filter plate	033090650000
7	Reactor (big)	041301060000
8	Electronic expansion valve	2002010200026
9	4-way valve	2002010100014
10	Water flow switch	040060620000
11	Fan motor	032051720000
12	Full set of sensors	Z35043000400
13	Compressor	031064030000
14	Titanium heat exchanger (Heat&Cool)	2001020100181
15	Evaporator	1202010200148
16	High pressure protection switch	040050630000
17	Low pressure protection switch	040050130000
18	Low Pressure valve	006080500000
19	Liquid reservoir	1203020300001
20	Water union (Black, 50mm)	003990020000
21	Water union gasket	004980050003
22	Fan	007010080000
23	Drainage kit	Z03991700000
24	Top cover	1220020104118
25	Front Panel	1220020302430
26	Right Up Panel	1220020302248
27	Back Panel	1220020302432
28	Bottom board	1220020104119
29	Back mesh board	1220020302431
30	Left mesh board	1220020302447